

# JVC

## SERVICE MANUAL

### PORTABLE MINIDISC PLAYER

# XM-PX70WT/BU/PN

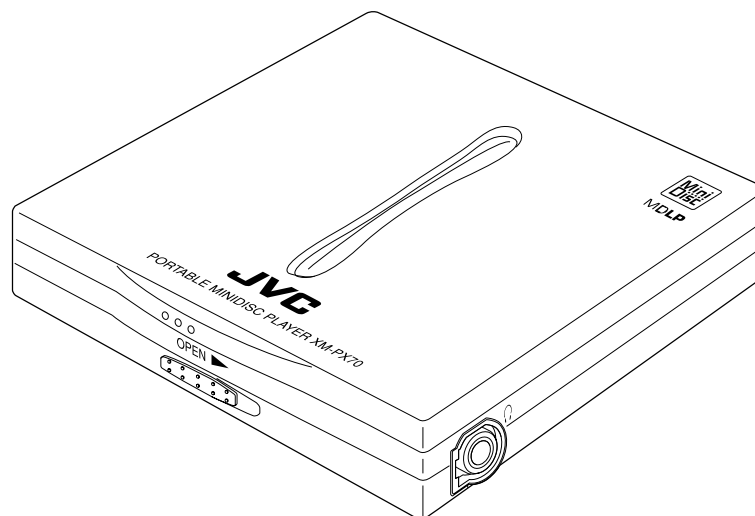

#### Area Suffix

UB ..... Hong Kong

### MDLP



### Contents

Safety Precautions .....	1-2
Attention when	
MD pick up is exchanged .....	1-3
Disassembly method .....	1-4
Adjustment method .....	1-9
Maintenance of laser pickup .....	1-10
Replacement of laser pickup .....	1-10
Description of major ICs .....	1-11
Attention when parts	
are exchanged .....	1-24

## Safety Precautions

1. This design of this product contains special hardware and many circuits and components specially for safety purposes. For continued protection, no changes should be made to the original design unless authorized in writing by the manufacturer. Replacement parts must be identical to those used in the original circuits. Services should be performed by qualified personnel only.
2. Alterations of the design or circuitry of the product should not be made. Any design alterations of the product should not be made. Any design alterations or additions will void the manufacturer's warranty and will further relieve the manufacture of responsibility for personal injury or property damage resulting therefrom.
3. Many electrical and mechanical parts in the products have special safety-related characteristics. These characteristics are often not evident from visual inspection nor can the protection afforded by them necessarily be obtained by using replacement components rated for higher voltage, wattage, etc. Replacement parts which have these special safety characteristics are identified in the Parts List of Service Manual. Electrical components having such features are identified by shading on the schematics and by ( $\triangle$ ) on the Parts List in the Service Manual. The use of a substitute replacement which does not have the same safety characteristics as the recommended replacement parts shown in the Parts List of Service Manual may create shock, fire, or other hazards.
4. The leads in the products are routed and dressed with ties, clamps, tubings, barriers and the like to be separated from live parts, high temperature parts, moving parts and/or sharp edges for the prevention of electric shock and fire hazard. When service is required, the original lead routing and dress should be observed, and it should be confirmed that they have been returned to normal, after re-assembling.
5. Leakage current check (Electrical shock hazard testing)  
After re-assembling the product, always perform an isolation check on the exposed metal parts of the product (antenna terminals, knobs, metal cabinet, screw heads, headphone jack, control shafts, etc.) to be sure the product is safe to operate without danger of electrical shock. Do not use a line isolation transformer during this check.

- Plug the AC line cord directly into the AC outlet. Using a "Leakage Current Tester", measure the leakage current from each exposed metal parts of the cabinet, particularly any exposed metal part having a return path to the chassis, to a known good earth ground. Any leakage current must not exceed 0.5mA AC (r.m.s.)

- Alternate check method

Plug the AC line cord directly into the AC outlet. Use an AC voltmeter having, 1,000 ohms per volt or more sensitivity in the following manner. Connect a 1,500 $\Omega$  10W resistor paralleled by a 0.15 $\mu$ F AC-type capacitor between an exposed metal part and a known good earth ground.

Measure the AC voltage across the resistor with the AC voltmeter.

Move the resistor connection to each exposed metal part, particularly any exposed metal part having a return path to the chassis, and measure the AC voltage across the resistor. Now, reverse the plug in the AC outlet and repeat each measurement. voltage measured Any must not exceed 0.75 V AC (r.m.s.). This corresponds to 0.5 mA AC (r.m.s.).

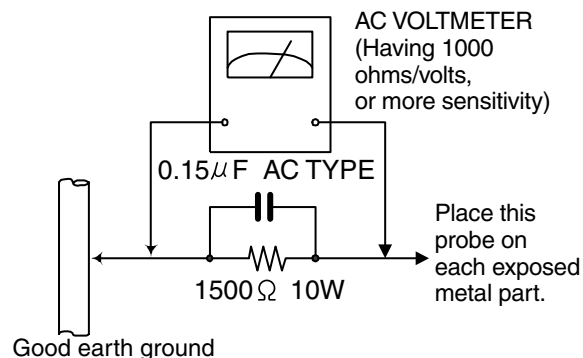

## Warning

1. This equipment has been designed and manufactured to meet international safety standards.
2. It is the legal responsibility of the repairer to ensure that these safety standards are maintained.
3. Repairs must be made in accordance with the relevant safety standards.
4. It is essential that safety critical components are replaced by approved parts.
5. If mains voltage selector is provided, check setting for local voltage.

**⚠ CAUTION** Burrs formed during molding may be left over on some parts of the chassis. Therefore, pay attention to such burrs in the case of preforming repair of this system.

## Attention when MD pickup is exchanged

### 1. About the static electricity protection measures

The laser diode in the traverse unit (optical pick up) is easy to be destroyed by clothes and the human body to the electrified static electricity.

Please note the explosion by static electricity when repairing.

### 2. About the earth processing for the electrostatic destruction prevention

In the equipment which uses an optical pick up (laser diode), an optical pick up is destroyed by the static electricity of the work environment.

Please do the earth processing and work.

#### 1) Earth of work stand

Please pull the conductive material (conductive sheet) or the iron plate to the depository place of the traverse unit (optical pick up), and take the earth to ground.

#### 2) Human body earth

Please use the anti-static wrist strap to exhaust the electrified static electricity to the human body.

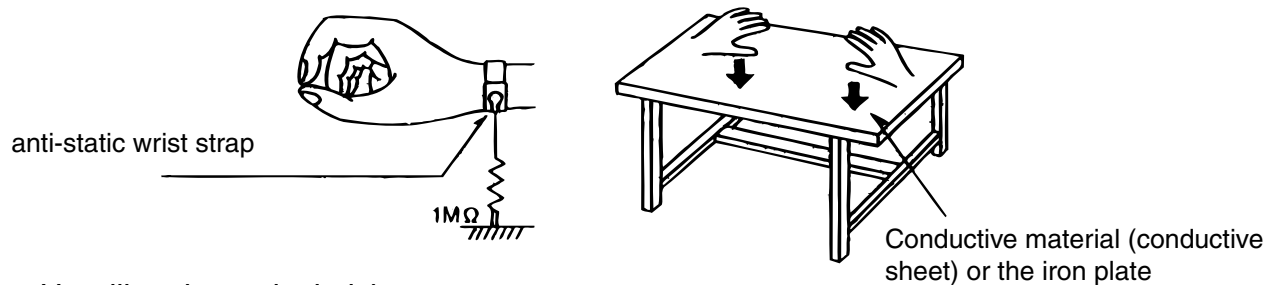

### 3. Handling the optical pick up

1) Please return according to a correct procedure based on short processing after exchanging parts.

2) Do not use a tester to check the condition of the laser diode in the optical pick up. The tester's internal power source can easily destroy the laser diode.

### 4. Attention when unit is disassembled

Please refer to "Disassembling method" for how to detach.

1) Please be sure to solder before a flexible wire is removed from connector on a main printed circuit board as shown.

if you removes without soldering.the MD picking up assembly might destroy

2) When installing, solder in the part of short round should be removed after a flexible wire is connected with connector.

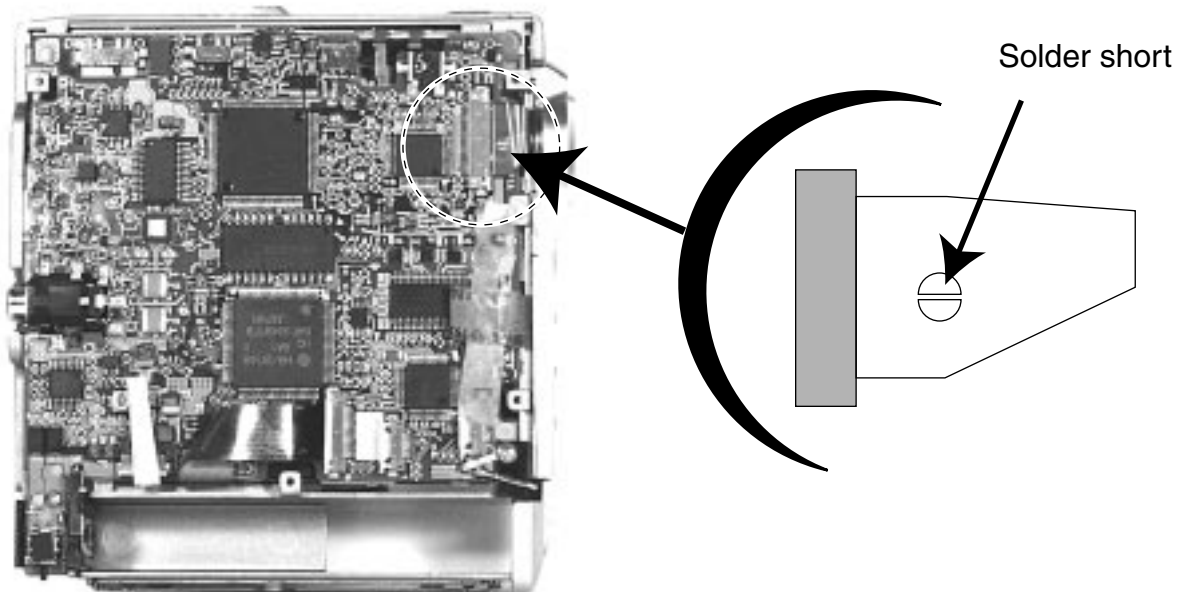

# Disassembly method

## ■ Removing the MD door assembly (See Fig.1 and 2)

1. Shift the door lever to open the door.
2. Remove the four screws **A** and detach the MD door assembly from the main body.

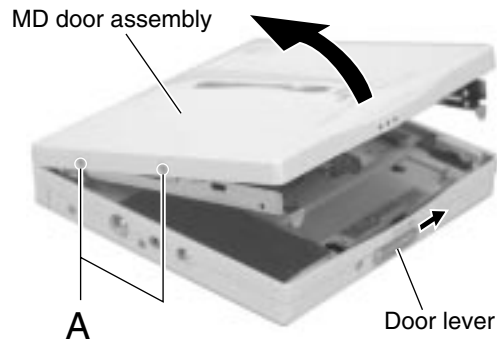

Fig.1

## ■ Removing the holder assembly (See Fig.3 and 4)

- Prior to performing the following procedure, remove the MD door assembly.

1. Turn the holder assembly as shown in Fig.3.
2. Pull the side arm (L) marked **a** and remove outward. Open the holder assembly as shown in Fig.4.
3. Move the marked **b** in the direction of the arrow and release it from the shaft.
4. Move the part **c** inward and pull out the holder assembly from the shaft.

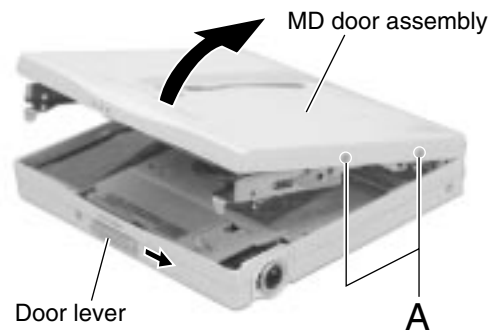

Fig.2

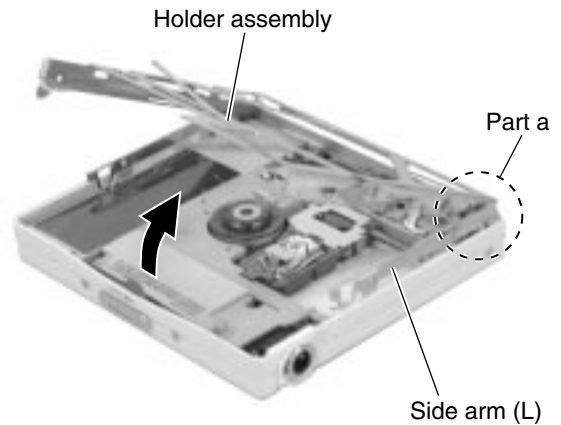

Fig.3

**ATTENTION:** When reassembling, first reattach the part **c** to the shaft of the chassis assembly. And next, fit the “U-shaped” notch to the shaft.

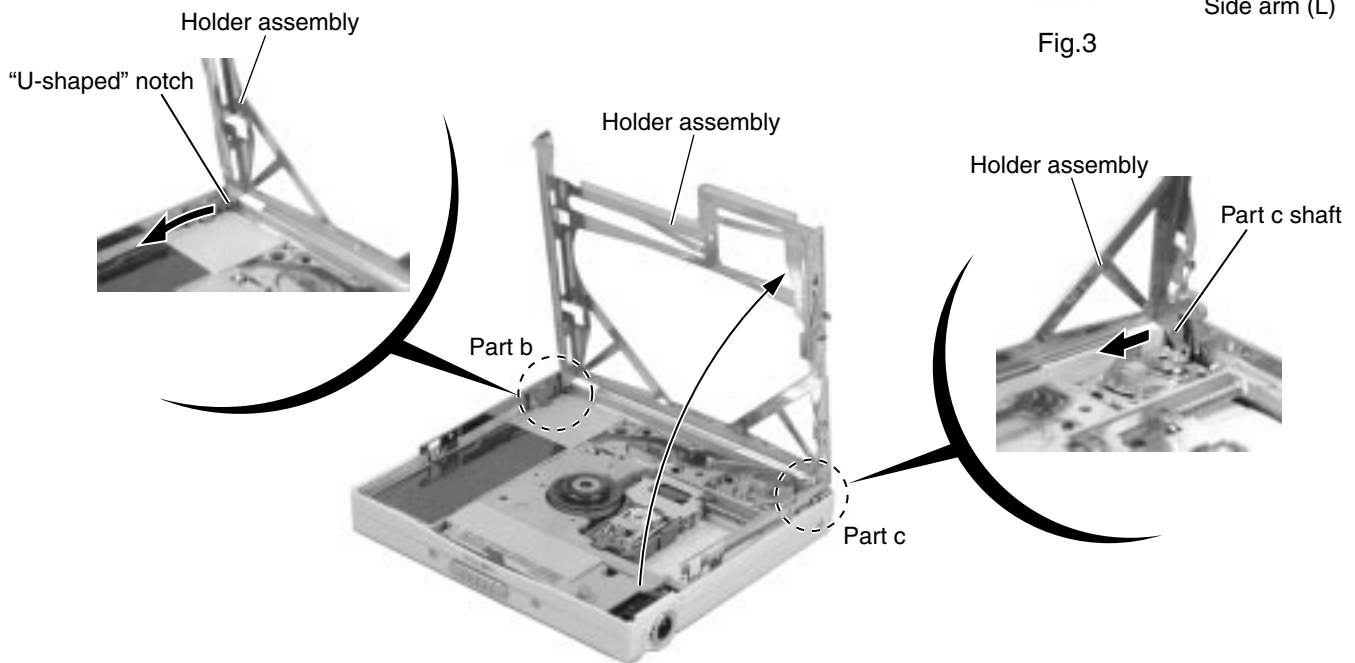
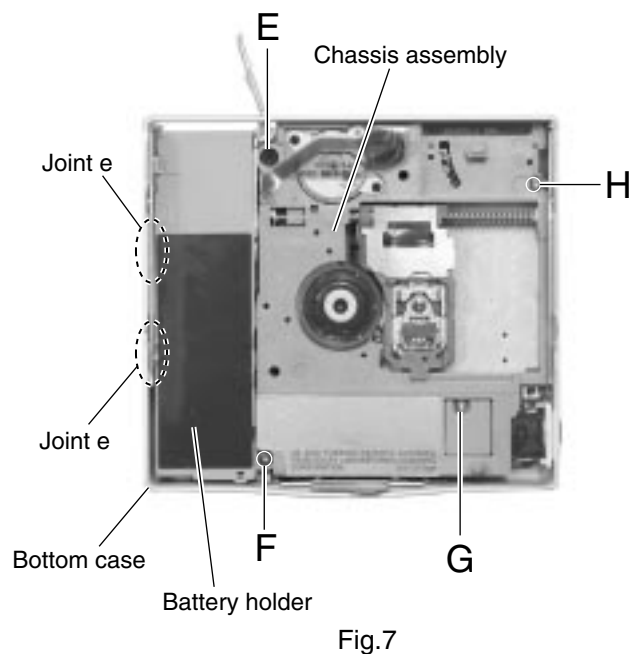
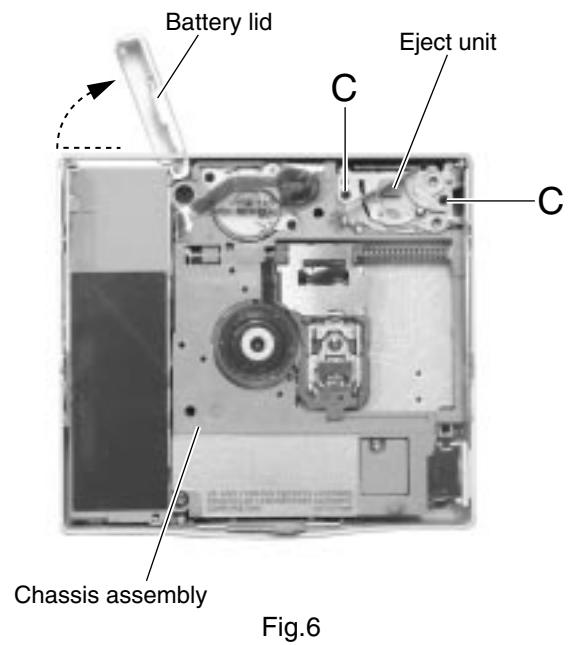
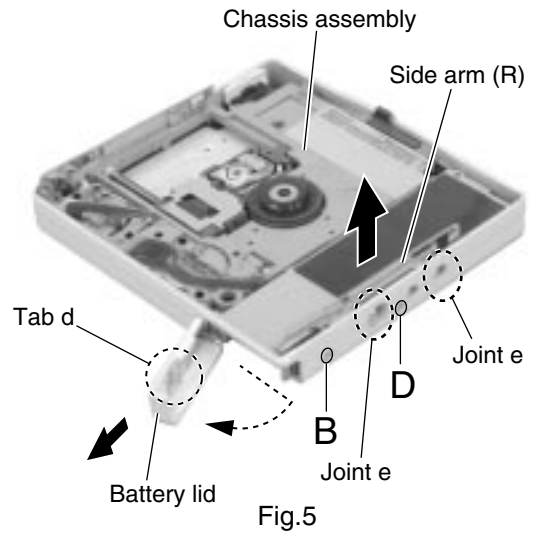

Fig.4

**■ Removing the chassis assembly**  
**(See Fig.5 to 7)**

· Prior to performing the following procedure, remove the MD door assembly and the holder assembly.

1. Open the battery lid. Release the tab **d** and pull out the battery lid.
2. Remove the screw **B** and pull out the side arm (R) upward.
3. Remove the two screws **C** and pull out the eject unit.
4. Remove the screw **D, E, F, G** and **H** attaching the chassis assembly respectively.
5. Disengage the three joints **e** of the bottom case and the battery holder. Remove the chassis assembly and the jack cover at once.



**■ Removing the main board and the battery holder (See Fig.8 and 9)**

- Prior to performing the following procedures, remove the MD door assembly, the holder assembly and the chassis assembly.

**ATTENTION:** Before disconnecting the flexible wire extending from the pickup, make sure to solder the short circuit round to prevent damage to the pickup.

1. Solder the short circuit round of the flexible wire on the main board.
2. Disconnect the flexible wires from connector CN301 and CN401 on the main board.
3. Remove the one screw **I** attaching the main board. Remove the main board with the battery holder .
4. Unsolder the four soldered parts **f** retaining the main board and the battery holder.

**ATTENTION:** When reassembling, connect the flexible wire extending from the pickup to the connector on the main board and unsolder the short circuit round.

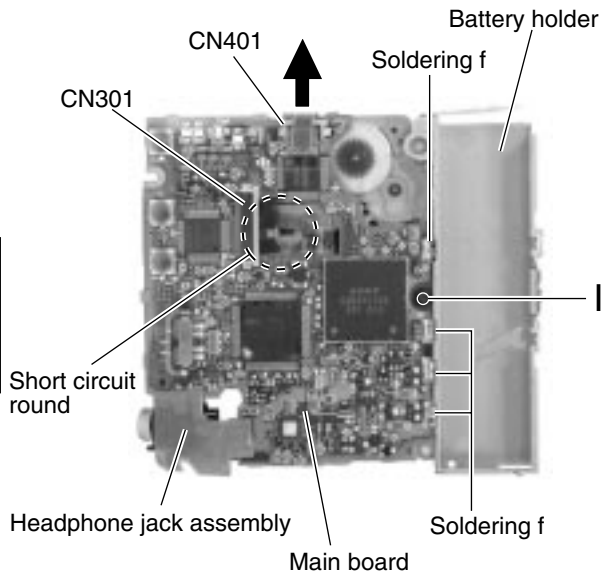

Fig.8

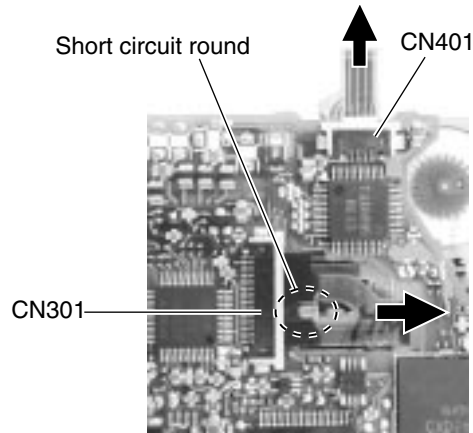

Fig.9

**■ Removing the headphone jack assembly (See Fig.10)**

- Prior to performing the following procedures, remove the MD door assembly, the holder assembly, chassis assembly and the main board.

1. Disconnect the flexible wire extending from the headphone jack from connector CN601 on the main board.

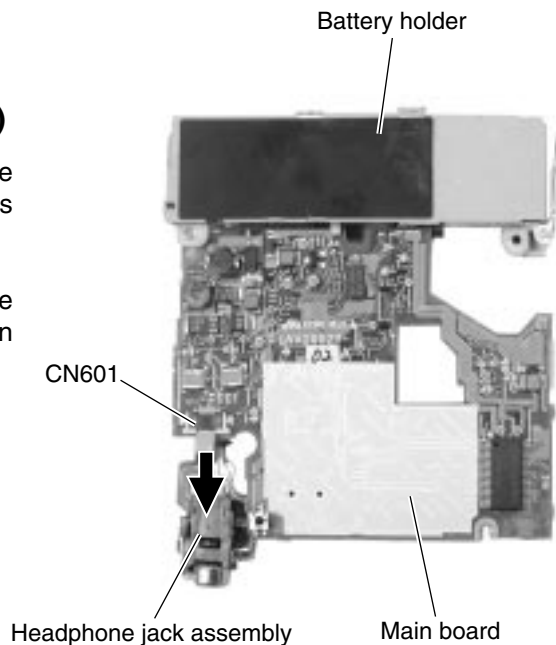

Fig.10

## <Removal of the MD mechanism section>

- Prior to performing the following procedures, remove the MD door assembly, the holder assembly, the chassis assembly and the main board.

### ■ Removing the spindle motor (See Fig.11)

1. Unsolder the part **g** on the flexible wire extending from the underside of the chassis assembly to the spindle motor.

ATTENTION: Do not spill flux on the gear and others.

2. Remove the three screws **J** attaching the spindle motor.

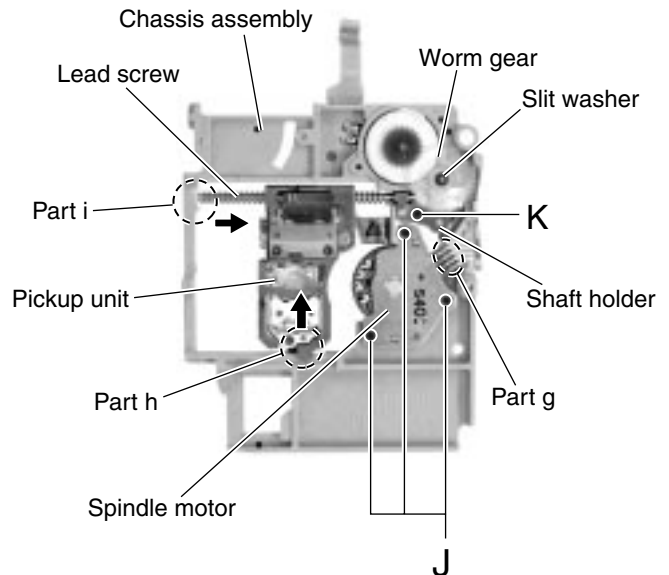

Fig.11

### ■ Removing the pickup unit (See Fig.11)

ATTENTION: When handling the pickup unit, touch the parts marked in Fig.13 only.

1. Remove the slit washer and the worm gear from the underside of the chassis assembly.
2. Remove the screw **K** attaching the shaft holder and draw out the shaft (lead screw).
3. Pull out the pickup unit and the lead screw while disengaging the part **h** and **i**.

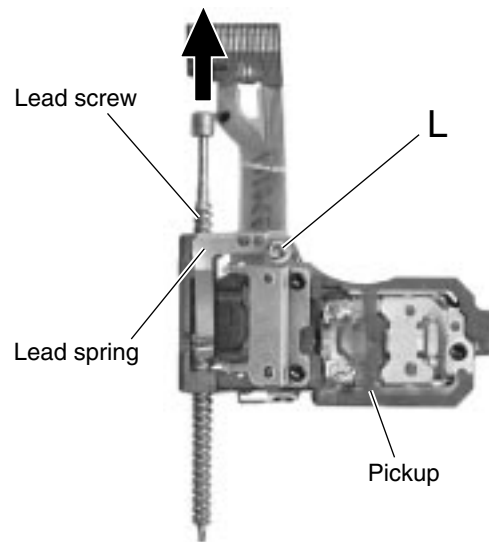

Fig.12

### ■ Removing the pickup (See Fig.12 and 13)

ATTENTION: When handling the pickup unit, touch the parts marked in Fig.13 only.

1. Remove the screw **L** and the lead spring.
2. Pull out the shaft from the pickup.

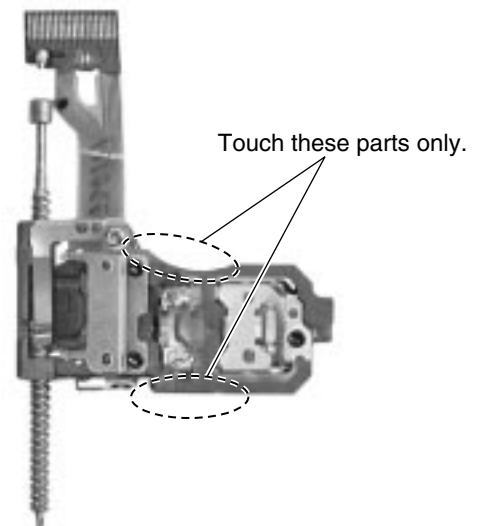

Fig.13

■ **Removing the feed motor (See Fig.14)**

1. Peel off the adhesive tape **j** on the flexible wire on the underside of the feed motor.
2. Unsolder soldering **k** connecting the flexible wire to the feed motor.
3. Remove the two screws **M** attaching the feed motor.

ATTENTION: When reassembling, reattach the flexible wire with an adhesive tape and solder.

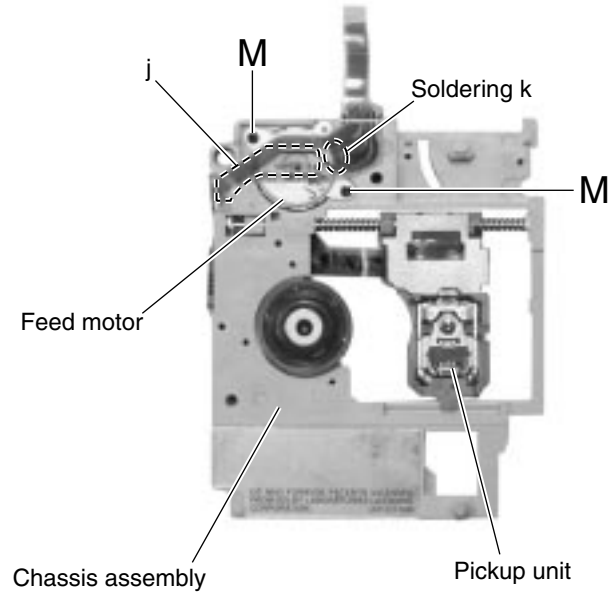

Fig.14



# Adjustment method

This model is auto adjustment by Remote Controller.  
Please adjust the attached remote controller.

- Equipments-----**
- |                                    |                           |
|------------------------------------|---------------------------|
| <b>1. Remote controller</b>        | <b>2. DC power supply</b> |
| <b>3. Laser power meter</b>        | <b>4. MO disc (AU-1)</b>  |
| <b>5. Pre master disc (TGYS 1)</b> |                           |

## <Test mode setting method>

Press < PLAY MODE + DISPLAY + BASS > and < PLAY >key together more than 3sec. at power off condition.  
< VOL- >→next item .< VOL+ >before item.

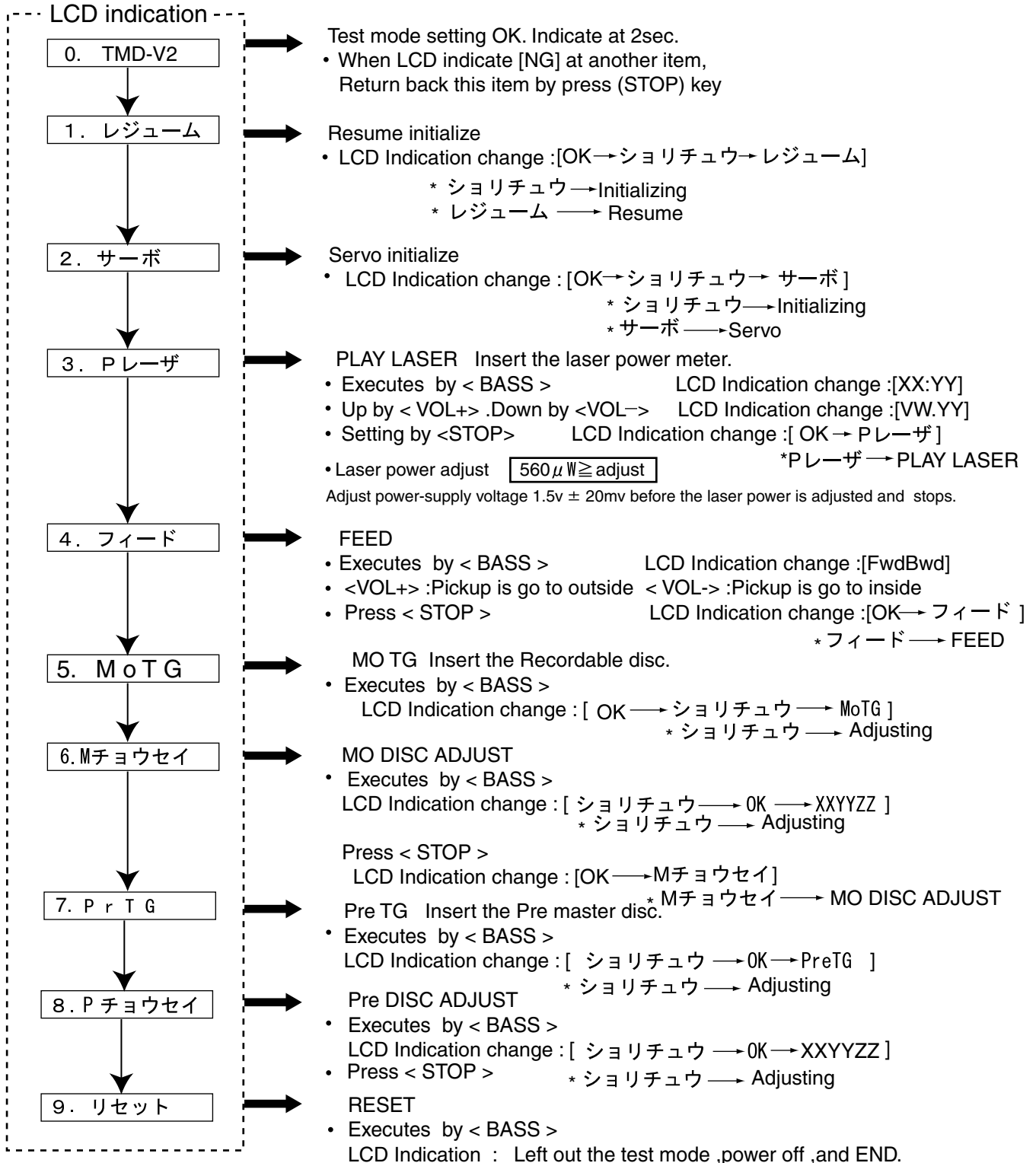

## Maintenance of laser pickup

## Replacement of laser pickup

(1) Cleaning the pick up lens

Before you replace the pick up, please try to clean the lens with a alcohol soaked cotton swab.

(2) Life of the laser diode

When the life of the laser diode has expired, the following symptoms will appear.

1. The level of RF output (EFM output: amplitude of eye pattern) will below.

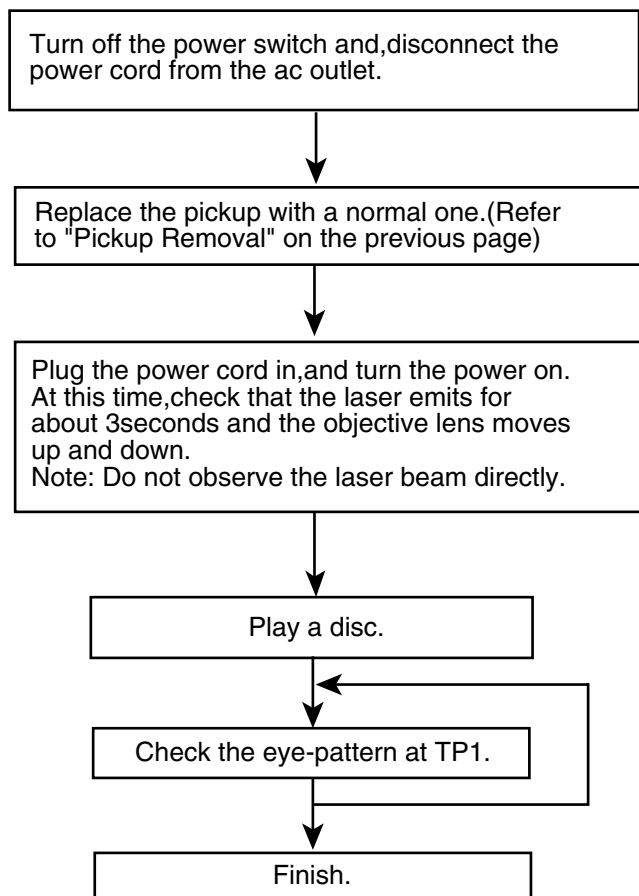
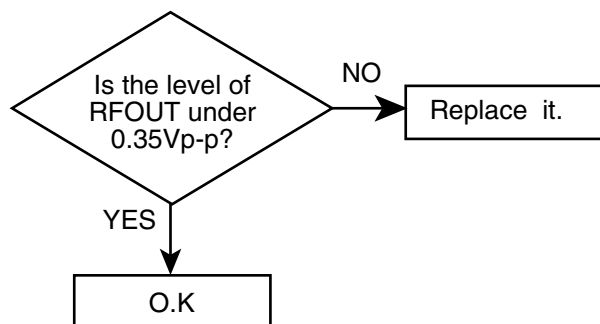

- (3) Semi-fixed resistor on the APC PC board The semi-fixed resistor on the APC printed circuit board which is attached to the pickup is used to adjust the laser power.Since this adjustment should be performed to match the characteristics of the whole optical block, do not touch the semi-fixed resistor.  
 If the laser power is lower than the specified value,the laser diode is almost worn out, and the laser pickup should be replaced.  
 If the semi-fixed resistor is adjusted while the pickup is functioning normally,the laser pickup may be damaged due to excessive current.

# Description of major ICs

## ■ JCV8002-W (IC601) : Head phone amp

### 1. Pin layout

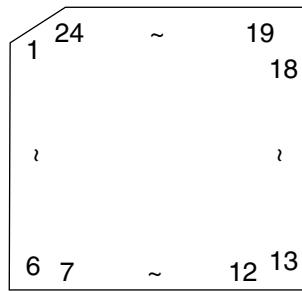

### 2. Block diagram

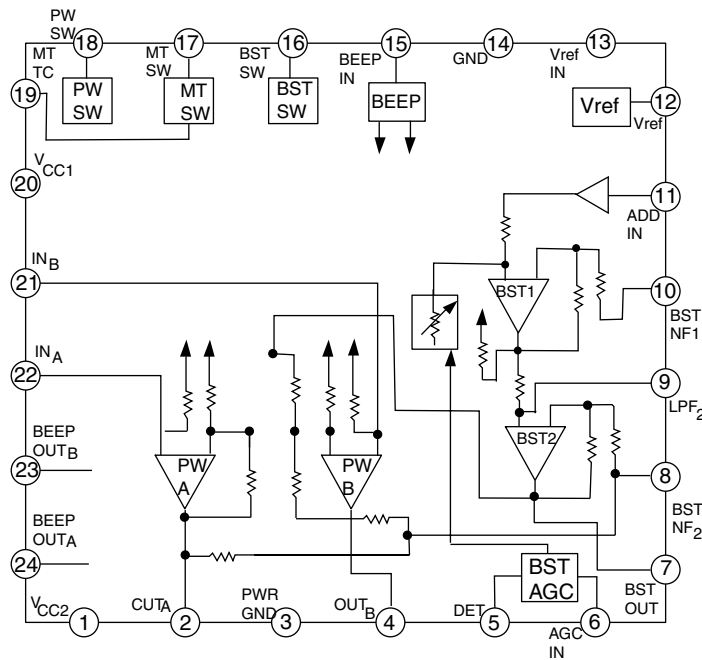

### 3. Pin function

Pin no.	Symbol	FUNCTION
1	V <sub>CC2</sub>	V <sub>CC2</sub> (+B) in power amplifier output steps
2	OUT <sub>A</sub>	Power amplifier output
3	PWR GND	GND in power amplifier output steps
4	OUT <sub>B</sub>	Power amplifier output
5	DET	Smoothness of level detection of boost AGC
6	AGC IN	BST amplifier input signal level variable control by input lever to boost AGC input terminal
7	BST OUT	Output terminal of BST amplifier2
8	BST NF <sub>2</sub>	Terminal NF of BST amplifier2
9	LPF <sub>2</sub>	Output BST amplifier1
10	BST NF <sub>1</sub>	NF of BST amplifier1
11	ADD IN	ADD amplifier input
12	V <sub>ref</sub>	Standard potential circuit
13	V <sub>ref</sub> IN	Standard potential circuit
14	GND	Power part input steps GND
15	BEEP IN	Beep input terminal
16	BST SW	Beep output terminal
17	MT SW	Mute switch
18	PW SW	Power On/OFF switch
19	MT TC	Mute smoothing Power mute switch
20	V <sub>CC1</sub>	Main parts V <sub>CC</sub>
21	IN <sub>B</sub>	Power amplifier input
22	IN <sub>A</sub>	Power amplifier input
23	BEEP OUT <sub>B</sub>	Beep output terminal
24	BEEP OUT <sub>A</sub>	Beep output terminal

■ CXA2588R (IC300) : RF amp.

1. Pin layout & block diagram

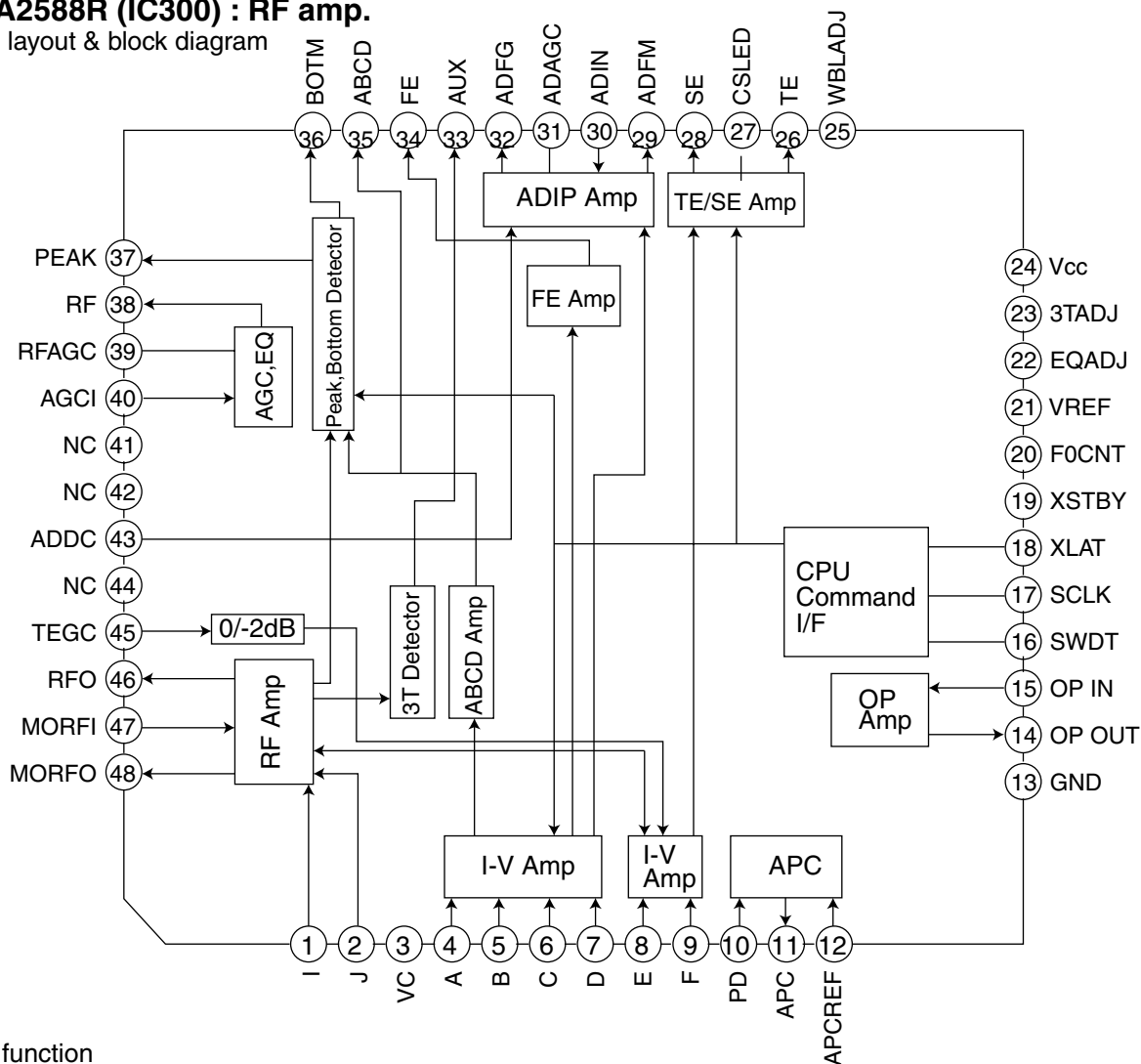

2. Pin function

Pin No.	Symbol	I/O	Function	Pin No.	Symbol	I/O	Function
1	I	I	I-V converted RF signal I input	25	WBLADJ	I/O	BPF3T IF setting terminal
2	J	I	I-V converted RF signal J input	26	TE	O	Tracking error signal output terminal
3	VC	O	Vcc/2 voltage output	27	CSLED	-	Sled error signal LPF capacitor connect terminal
4	A	I	A current input for main beam servo signal	28	SE	O	Sled error signal output terminal
5	B	I	B current input for main beam servo signal	29	ADFM	O	ADIP FM signal output terminal
6	C	I	C current input for main beam servo signal	30	ADIN	I	ADIP signal completer input terminal
7	D	I	D current input for main beam servo signal	31	ADAGC	-	ADIP AGC capacitor connect terminal
8	E	I	E current input for side beam servo signal	32	ADFG	O	ADIP binary signal output
9	F	I	F current input for side beam servo signal	33	AUX	O	I3 output/temp.signal output
10	PD	I	Reflection light q'ty monitor signal input	34	FE	O	Focus error signal output
11	APC	O	Laser APC output	35	ABCD	O	Reflection light q'ty signal output for main beam servo detector
12	APCREF	I	Ref. voltage input for laser power intensity setting	36	BOTM	O	RF/ABCD bottom-hold signal output
13	GND	-	Ground	37	PEAK	O	RF/ABCD peak-hold signal output
14	OPOUT	O	Ope. amp output terminal	38	RF	O	RF equalizer output
15	OPIN	I	21dB ope. amp input terminal	39	RFAGC	-	RFAGC capacitor connection
16	SWDT	I	Serial data input terminal	40	AGCI	I	RFAGC input
17	SCLK	I	Shift clock input terminal	41	NC	-	Non connect
18	XLAT	I	Latch input terminal	42	NC	-	Non connect
19	XSTBY	I	Stand by setting terminal	43	ADDC	I/O	ADIP amp. feedback circuit capacitor connection
20	F0CNT	I	F0 count setting terminal	44	NC	-	Non connection
21	VREF	O	Reference voltage output terminal	45	TEGC	I	TE amp. gain switching
22	EQADJ	I/O	EQ IF setting terminal	46	RFO	O	RF amp. output
23	3TADJ	I/O	BPF3T IF setting terminal	47	MORFI	I	Groove RF signal AC-coupled input
24	Vcc	-	Power supply	48	MORFO	O	Groove RF signal output

■ CXA8059Q (IC450) : Motor driver

1. Pin layout

	36	~	25
	37		24
	~		~
	48		13
○ 1	~		12

2. Block diagram

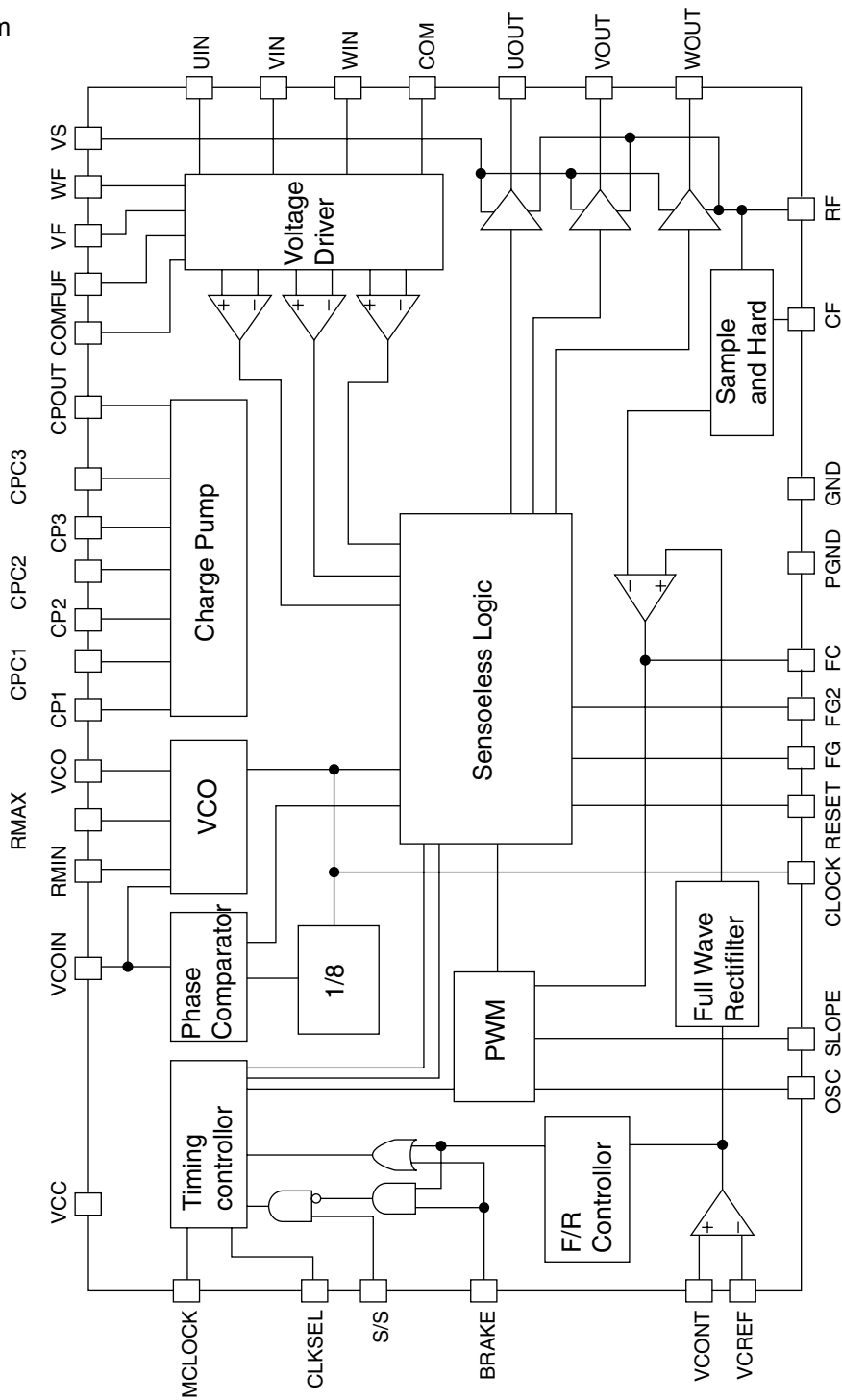

## 3.Pin function

Pin no.	Symbol	Function
1	PGND	The GND to guard the power stage.
2	COM	The terminal to detect the voltage.
3	VS	The terminal to supply the voltage for the power stage.
4	CPOUT	The terminal to connect the capacitor in the final charge pump.
5	CPC3	The terminal to connect the capacitor in the third charge pump.
6	CP3	The terminal to connect the capacitor in the third charge pump.
7	CPC2	The terminal to connect the capacitor in the second charge pump.
8	CP2	The terminal to connect the capacitor in the second charge pump.
9	CPC1	The terminal to connect the capacitor in the first charge pump.
10	CP1	The terminal to connect the capacitor in the first charge pump.
11	GND	The GND for the part except the power section.
12	S/S	The terminal for start and stop.
13	BRAKE	The terminal for braking.
14	VCONT	The terminal for controlling velocity.
15	VCREF	The terminal as referable voltage of controlling velocity.
16	FC	The terminal to compensate the frequency characteristics of the loop controlling velocity.
17	CF	The terminal of sampling and holding for detecting motor current.
18	FG	The terminal to output FG pulse.
19	FG2	The terminal to output FG pulse divided Pin15 signal by 2.
20	VCO	The terminal to set oscillation frequency of VCO.
21	RMAX	The terminal to set maximum oscillation frequency of VCO.
22	RMIN	The terminal to set minimum oscillation frequency of VCO.
23	VCOIN	The terminal to control oscillation frequency of VCO.
24	CLKSEL	The terminal to select inside and outside clock.
25	OSC	The terminal to oscillation sawtooth for PWM signal.
26	SLOPE	The terminal to oscillation sawtooth for soft-switching signal.
27	CLOCK	The terminal to monitor CLOCK signal.
28	GND	The GND for the part except the power section.
29	WF	The terminal to shape waveform of motor voltage.
30	VF	The terminal to shape waveform of motor voltage.
31	UF	The terminal to shape waveform of motor voltage.
32	COMF	The terminal to shape waveform of motor voltage.
33	VCC	The terminal to supply the voltage except the power section.
34	MCLOCK	The terminal to input clock.
35	VS	The terminal to supply the voltage for the power stage.
36	RESET	The terminal to reset a register for checking the movement.
37	RF	The terminal to monitor current.
38	NC	Non connect
39	NC	Non connect
40	WIN	The terminal to sense the back electro magnetic force of coils.
41	WOUT	The terminal to supply the motor current.
42	VIN	The terminal to sense the back electro magnetic force of coils.
43	VOUT	The terminal to supply the motor current.
44	UIN	The terminal to sense the back electro magnetic force of coils.
45	UOUT	The terminal to supply the motor current.
46	NC	Non connect
47	NC	Non connect
48	RF	The terminal to monitor current.

**■ CXD2672GA(IC351):DSP**

1.Pin layout

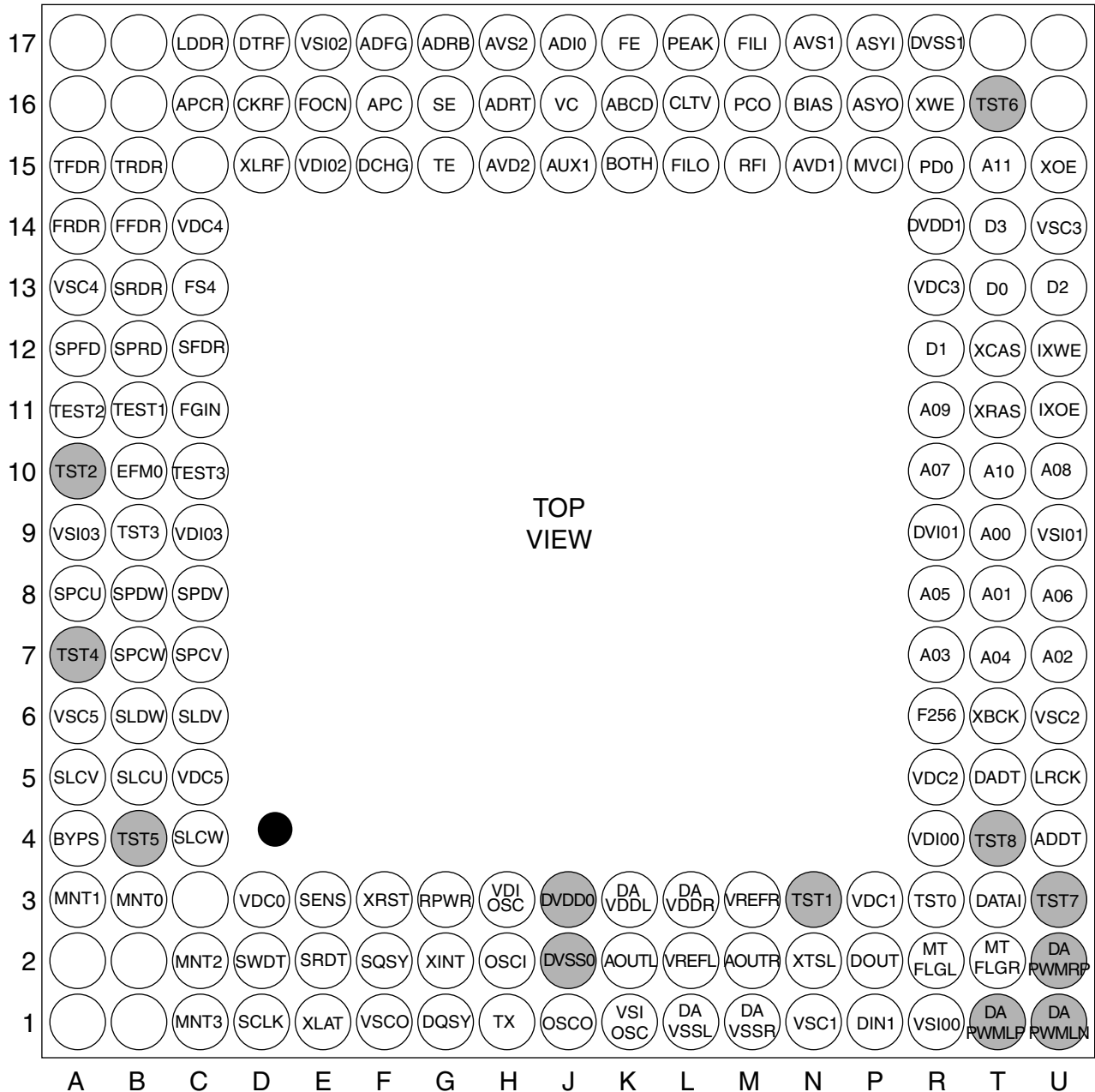

2.Pin function (1)

Pin No.	Symbol	I/O	Function
A-1	NC	-	Open
A-2	NC	-	Open
A-3	NC	-	Open
B-1	MNT1	O	Monitor output
B-2	NC	-	Open
B-3	NC	-	Open
C-1	MNT0	I/O	Monitor in/output
C-2	MNT3	O	Monitor output
C-3	MNT2	O	Monitor output
D-1	NC	-	Open
D-2	SCLK	I	Micon serial bus clock input
D-3	SWDT	I	Micon serial bus data write input
	VDC0	-	Internal logic VDD(1.8V)

## 2.Pin function(2)

Pin No.	Symbol	I/O	Function
E-1	XLAT	I	Micon serial bus latch input
E-2	SRDT	O	Micon serial bus data read out output
E-3	SENS	O	Internal output of micon serial bus address
F-1	VSC0	-	Internal logic GND
F-2	SQSY	O	PTGR=0 ADIPsink output / PTGR=1 DISC SUB-Q sink output
F-3	XRST	I	Reset input L:reset
G-1	DQSY	O	Ubit SUB-Q sink output from digital audio input from MD or CD
G-2	XINT	O	Request status output L:request status
G-3	RPWR	I	Laser power select input (H=rec power / L=playback power)
H-1	TX	I	Output permit input of recorded data
H-2	OSCI	I	X'tal osc circuit input
H-3	VDIOSC	-	OSC sel VDD (2.5V)
J-1	OSCO	O	X'tal osc circuit output
J-2	DVSS0	-	Internal 16bit DRAM GND
J-3	DVDD0	-	Internal 16bit DRAM GND
K-1	VSIOSC	-	OSC sel GND
K-2	AOUTL	O	Internal DAC Lch output
K-3	DAVDDL	-	Internal DAC VDD (Lch,2.5V)
L-1	DAVSSL	-	Internal DAC GND
L-2	VREFL	O	Internal DAC GND VREF(Lch)
L-3	DAVDDR	-	Internal DAC VDD (Rch,2.5V)
M-1	DAVSSR	-	Internal DAC GND (Rch)
M-2	AOUTR	O	Internal DAC Rch output
M-3	VREFR	O	Internal DAC VREF (Rch)
N-1	VSC1	-	Internal logic GND
N-2	XTSL	I	X'tal frequency select (L=45.1584MHz/H=22.5792MHz)
N-3	TST1	I	Test terminal Connect to GND
P-1	DIN1	I	Digital audio input Outer I/F mode EXRQ input
P-2	DOUT	O	Digital audio output
P-3	VDC1	-	Internal logic VDD (1.8V)
U-1	DAPWMLN	O	Internal DAC PWM output L-
T-1	DAPWMLP	O	Internal DAC PWM output L+
R-1	VSIO0	-	2.5V I/O VSS
U-2	DAPWMRP	O	Internal DAC PWM output R+
T-2	MTFLGR	O	Internal DAC zero detect flag (Rch)
R-2	MTFLGL	O	Internal DAC zero detect flag (Lch)
U-3	TST7	I	Test terminal Connect to GND
T-3	DATAI	I	Serial data input
R-3	TST0	O	Open
U-4	ADDT	I	Data input from A/D converter
T-4	TST8	I	Test terminal Connect to GND
R-4	VDIO0	-	2.5V I/O VDD
U-5	LRCK	O	LR clock(44.1kHz) for A/D, internal DAC
T-5	DADT	O	Data output for internal DAC / Internal DAC PWM output R-
R-5	VDC2	-	Internal logic VDD (1.8V)
U-6	VSC2	-	Internal logic GND
T-6	XBCK	O	A/D, internal DAC bit clock (2.8224MHz)
R-6	F256	O	11.2896MHz clock output (X'tal)
U-7	A02	O	External DRAM address output
T-7	A04	O	External DRAM address output
R-7	A03	O	External DRAM address output
U-8	A06	O	External DRAM address output
T-8	A01	O	External DRAM address output
R-8	A05	O	External DRAM address output



## 2.Pin function (3)

Pin No.	Symbol	I/O	Function
U-9	VSIO1	-	2.5V I/O sel Vss
T-9	A00	O	External DRAM address output
R-9	ADIO1	-	2.5V I/O sel VDD
U-10	A08	O	External DRAM address output
T-10	A10	O	External DRAM address output
R-10	A07	O	External DRAM address output
U-11	IXOE	O	Open
T-11	XRAS	O	External DRAM RAS output
R-11	A09	O	External DRAM address output
U-12	IXWE	O	Open
T-12	XCAS	O	External DRAM CAS output
R-12	D1	I/O	External DRAM data input/output
U-13	D2	I/O	External DRAM data input/output
T-13	D0	I/O	External DRAM data input/output
R-13	VDC3	-	Internal logic VDD
U-14	VSC3	-	Internal logic GND
T-14	D3	I/O	External DRAM data input/output
R-14	DVDD1	-	Internal 16Mbit DRAM VDD
U-17	NC	-	Open
U-16	NC	-	Open
U-15	XOE	O	External DRAM output chip enable output
T-17	NC	-	Open
T-16	TST6	O	Open
T-15	A11	O	Open
R-17	DVSS1	-	Internal 16Mbit DRAM GND
R-16	XWE	O	External DRAM write enable output
R-15	PDO	O	Analog PLL phase compare output
P-17	ASYI	I	Playback EFM comparator slice level input
P-16	ASYO	O	Playback EFM binarization signal output
P-15	MVCI	I	Clock input from external VCO
N-17	AVS1	-	Analog GND
N-16	BIAS	I	Playback EFM comparator bias current input
N-15	AVD1	O	Analog power supply (2.5V)
M-17	FILI	I	Filter input for playback EFM system mastering PLL
M-16	PCO	I	Phase comparison output for playback EFM system mastering PLL
M-15	RFI	I	Playback EFM RF signal input
L-17	PEAK	O	Peak holding input optical amount signal
L-16	CLTV	I	Internal VCO control voltage input for playback EFM system mastering PLL
L-15	FILO	I	Filter output for playback EFM system mastering PLL
K-17	FE	I	Focus error signal input
K-16	ABCD	O	Optical amount signal input
K-15	BOTOM	I	Bottom holding input of optical amount signal
J-17	ADIO	I	Open
J-16	VC	-	Middle point voltage input
J-15	AUX1	I	Assistance A/D input
H-17	AVS2	-	Analog GND
H-16	ADRT	I	A/D converter operation range upper bound voltage input
H-15	AVD2	-	Analog power supply (2.5V)
G-17	ADRB	I	A/D converter operation range lower bound voltage input
G-16	SE	I	Sled error input
G-15	TE	I	Tracking error input
F-17	ADFG	I	ADIP binary-coded FM signal input
F-16	APC	I	Error signal input for laser digital APC
F-15	DCHG	I	Connects with an analog power supply of low impedance

## 2.Pin function (4)

Pin No.	Symbol	I/O	Function
E-17	VSIO2	-	2.5V I/O Vss
E-16	F0CN	O	Filter cutoff control output
E-15	VDIO2	-	2.5V I/O VDD
D-17	DTRF	O	Controller data output
D-16	CKRF	O	Controller clock output
D-15	XLRF	O	Controller latch output
A-17	NC	-	Open
B-17	NC	-	Open
C-17	LDDR	O	Laser digital APC PWM output
A-16	NC	-	Open
B-16	NC	-	Open
C-16	APCR	O	Laser APC reference PWM output
A-15	TFDR	O	Tracking servo drive PWM output (+)
B-15	TRDR	O	Tracking servo drive PWM output (-)
C-15	NC	-	Open
A-14	FRDR	O	Focus servo drive PWM output (-)
B-14	FFDR	O	Focus servo drive PWM output (+)
C-14	VDC4	-	Internal logic VDD (1.8V)
A-13	VSC4	-	Internal logic GND
B-13	SRDR	O	Sled servo drive PWM output (-)
C-13	FS4	O	176.4kHz clock output (X'tal system)
A-12	SPFD	O	Spindle servo drive output
B-12	SPRD	O	Spindle servo drive output
C-12	SFRD	O	Sled servo drive PWM output (+)
A-11	TEST2	I	Test terminal Connect to GND
B-11	TEST1	I	Test terminal Connect to GND
C-11	FGIN	I	Spindle CAV servo FG input
A-10	TST2	O	Test terminal Open
B-10	EFMO	O	EFM output at recording
C-10	TEST3	I	Test terminal Connect to GND
A-9	VSIO3	-	2.5V I/O Vss
B-9	TST3	O	Test terminal Open
C-9	VDIO3	-	2.5V I/O VDD
A-8	SPCU	I	Blush less spindle motor drive comparete input (U)
B-8	SPDW	O	Blush less spindle motor 3 phase drive truth output (W)
C-8	SPDV	O	Blush less spindle motor 3 phase drive truth output (V)
A-7	TST4	O	Test terminal Open
B-7	SPCW	I	Blush less spindle motor drive comparete input (W)
C-7	SPCV	I	Blush less spindle motor drive comparete input (V)
A-6	VSC5	-	Internal logic GND
B-6	SLDW	O	Blush less sled motor 3 phase drive truth output (W)
C-6	SLDV	O	Blush less sled motor 3 phase drive truth output (V)
A-5	SLCV	I	Blush less sled motor 3 phase drive comparete input (V)
B-5	SLCU	I	Blush less sled motor 3 phase drive comparete input (U)
C-5	VDC5	-	Internal logic VDD (1.8V)
A-4	BYPS	O	Open
B-4	TST5	O	Test terminal Open
C-4	SLCW	I/O	Blush less sled motor 3 phase drive comparete input

■ AK93C55BH-W (IC502) : EEPROM

1. Pin layout

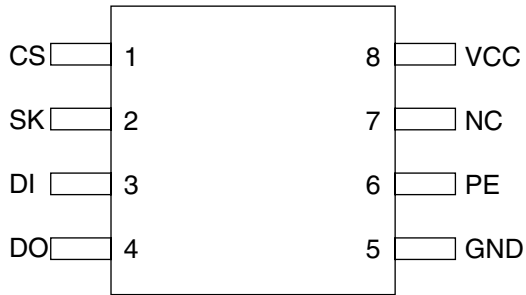

2. Pin function

Pin name	Fncion
CS	Chip select
SK	Serial data clock
DI	Serial data input
DO	Serial data output
PE	Program enable
VCC	Ground
GND	Power supply
NC	Not connected

3. Block diagram

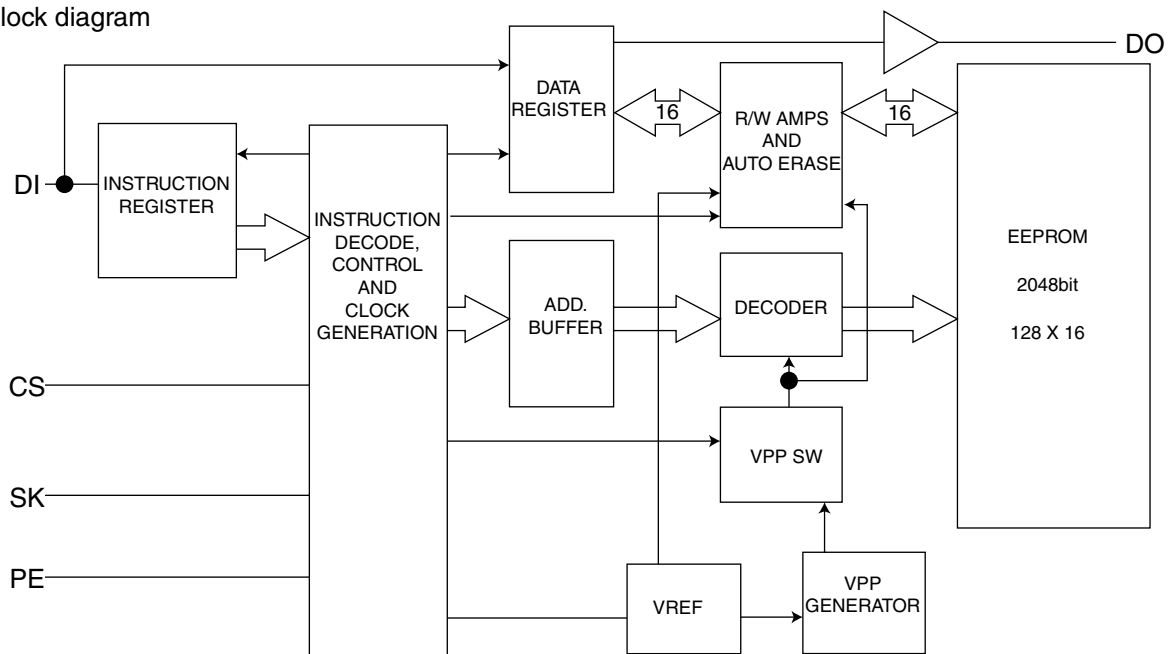

■ IC-PST3421U-X(IC504):System reset

1.Pin layout

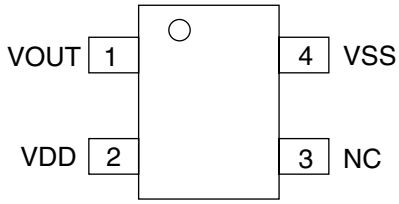

2.Pin function

Pin No.	Symbol	Function
1	VOUT	Reset signal output terminal
2	VDD	Power supply terminal
3	NC	Non connect
4	VSS	VSS terminal

3.Block diagram

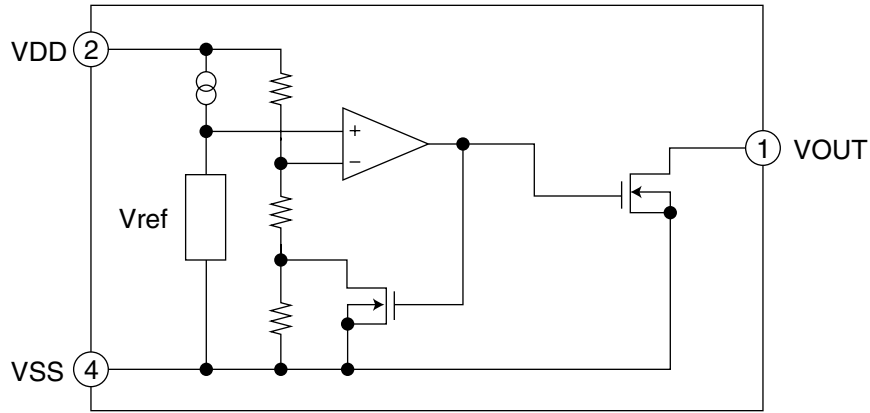

■ MPC17A139MTB-X (IC400) : 4ch bridge driver

1.Pin layout

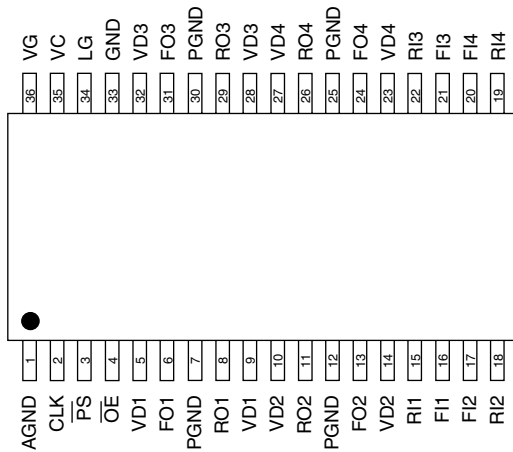

2.Pin function

Driver section

$\overline{PS}, \overline{OE}$		INPUT		OUTPUT 1~4	
$\overline{PS}$	$\overline{OE}$	FI	RI	FO	RO
H	L	L	L	L	L
H	L	L	H	L	H
H	L	H	L	H	L
H	L	H	H	L	L
H	H	X	X	L	L
L	X	X	X	Z	Z

X:Don't Care  
Z:High Impedance

Clock detector section

CLK	$\overline{PS}$	OSC circuit
X	H	Auto
	H	Syncro
X	L	Stop

3.Block diagram

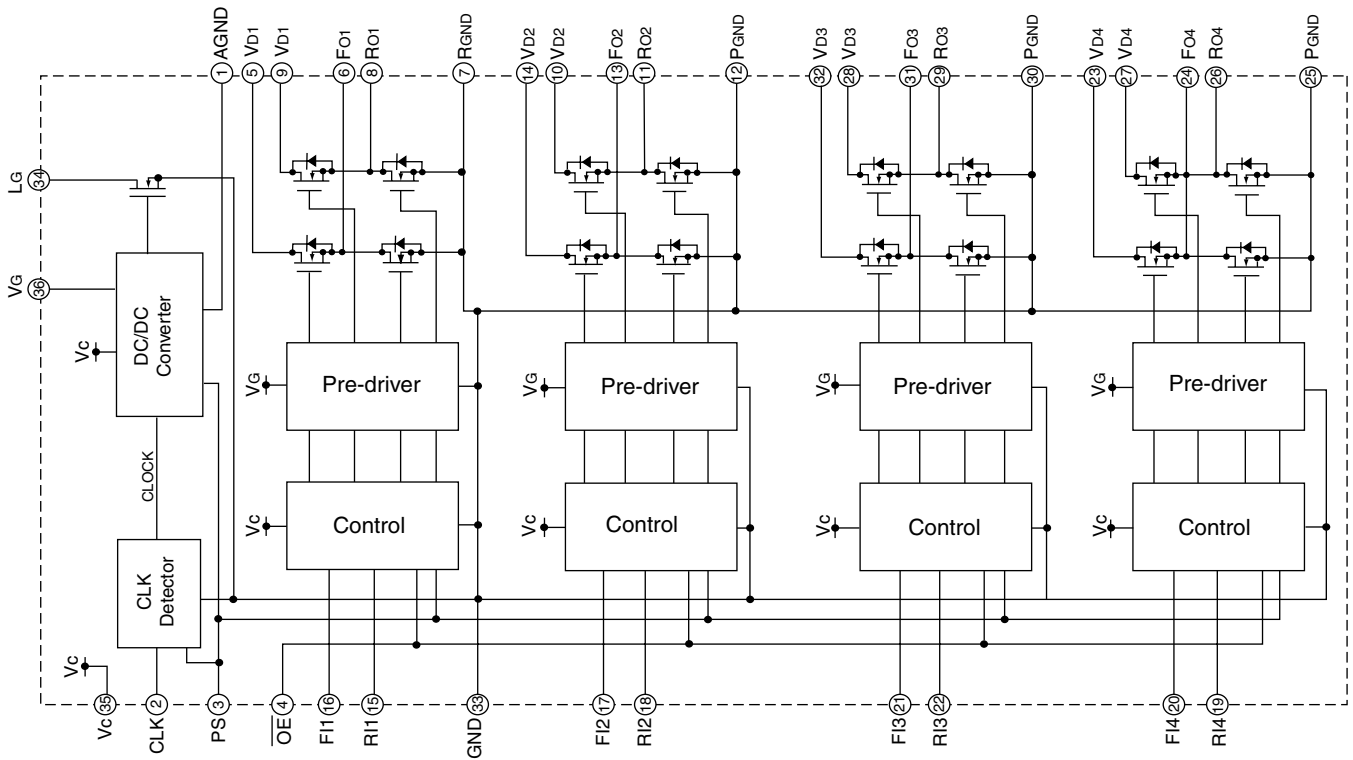

■ UPD784225GK-617C(IC501):CPU

1.Pin layout

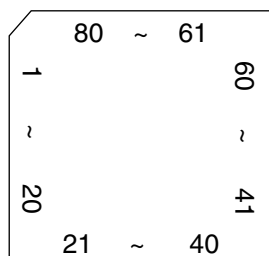

2.Pin function

Pin No.	Symbol	Function	Pin No.	Symbol	Function
1	ANI5	GND	41	-	Non connect
2	ANI6	GND	42	-	Non connect
3	SPSEL	Non connect	43	-	Non connect
4	AVSS	GND	44	-	Test terminal
5	-	Non connect	45	DPON	Test terminal
6	VADJ	Voltage adjust	46	-	Non connect
7	AVREF1	Analog reference voltage	47	RFVCTL	Test terminal
8	RMRX	Remocon data input terminal	48	PSAVE	Non connect
9	RMTX	Remocon data output terminal	49	RPON	RP ON signal input terminal
10	-	Non connect	50	DPON	DP ON signal input terminal
11	SRDT	Serial data read input terminal	51	REMOFF	Remocon OFF signal output terminal
12	SWDT	Serial data write input terminal	52	CS2	Chip select 2
13	SCLK	Serial bus clock output terminal	53	SCL	Serial clock signal output terminal
14	-	Non connect	54	DI	Data output terminal
15	BEEP	BEEP output terminal	55	CS1	Chip select 1
16	PSW	Power ON/OFF output terminal	56	MNT0	Monitor 0 input terminal
17	MONDATA	Test terminal	57	MNT3	Monitor 3 input terminal
18	MONCLK	Test terminal	58	SENS	DSP internal status input terminal
19	XRST2	Standby setting output terminal	59	DO	Data input terminal
20	TG	Tracking gain setting terminal	60	RESET	Reset signal input terminal
21	ACB	Non connect	61	XINT	Interrupt status data input terminal
22	TRAIN	Non connect	62	SQSY	Sink input terminal
23	XRST	Reset signal output terminal	63	-	Non connect
24	XLAT	Serial bus latch output terminal	64	RPLY	Remocon PLAY detect terminal
25	LVCTL	LSI power supply control signal output	65	DOOR	Door open/close detect terminal
26	LDON	Laser diode ON signal output terminal	66	PLAYKEY	PLAY key detect terminal
27	RFOFF	RF OFF signal input terminal	67	VSS0	GND
28	SLOFF	Sled OFF signal output terminal	68	VDD1	Reference voltage terminal
29	-	Non connect	69	X2	Connect to X'tal osc
30	MUTE	Mute signal output terminal	70	X1	Connect to X'tal osc
31	-	Mon connect	71	VPP	Test terminal
32	DIR	Test terminal	72	XT2	Non connect
33	VSS1	GND	73	XT1	GND
34	PS	Standby mode output terminal	74	VDD0	GND
35	SS	Start/Stop output terminal	75	AVD0	Reference voltage terminal
36	MON1	Test terminal	76	KEY	Remocon STOP key detect terminal
37	MON2	Test terminal	77	BATTERY	Battery voltage detect terminal
38	MONXLAT	Test terminal	78	TEMP	Connect to temp. detect
39	-	Non connect	79	ANI3	GND
40	-	Non connect	80	ANI4	GND

■ XC6367B101M-X (IC901,IC921,IC941):Regulator

1.Pin layout

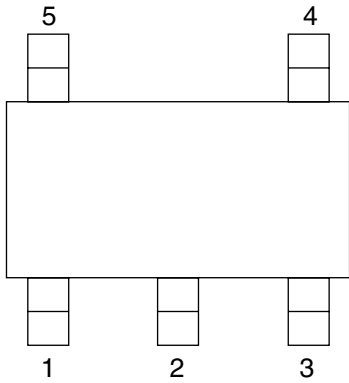

2.Pin function

Pin No.	Symbol	Function
1	FB	Output voltage setting
2	VDD	Power supply
3	CE	Chip enable
4	GND	GND
5	EXT	Ext. Tr connection

3.Block diagram

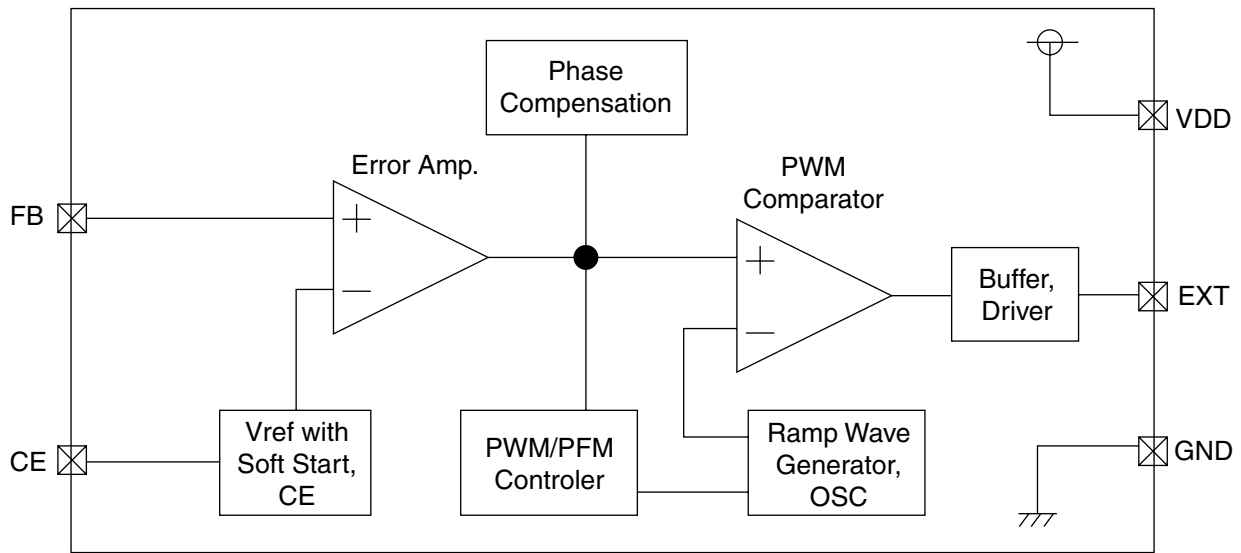

## Attention when parts are exchanged

The ② bottom case and ③⑤ MD door assembly are indicated on Exploded view of general assembly, there are two kind of parts at same color.

When you exchange parts confirm the marking and change same parts.

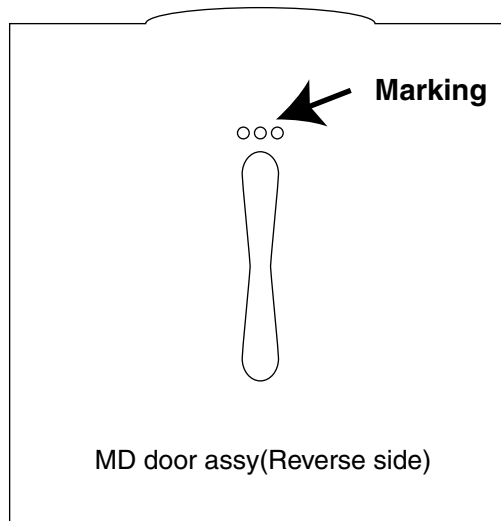
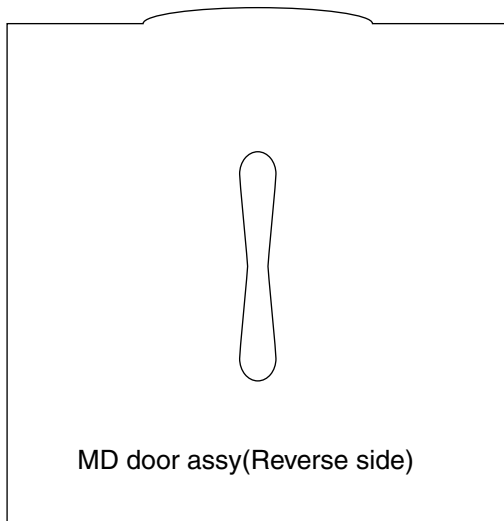
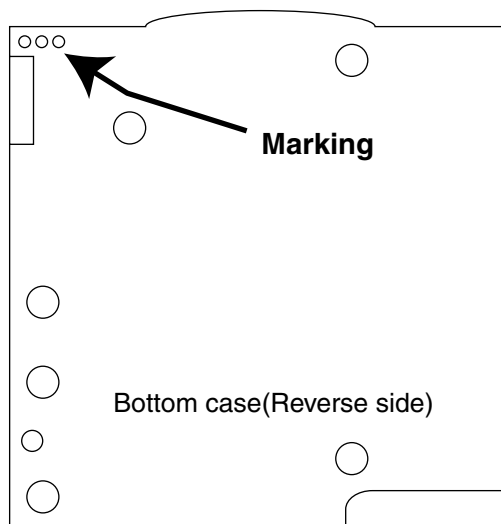
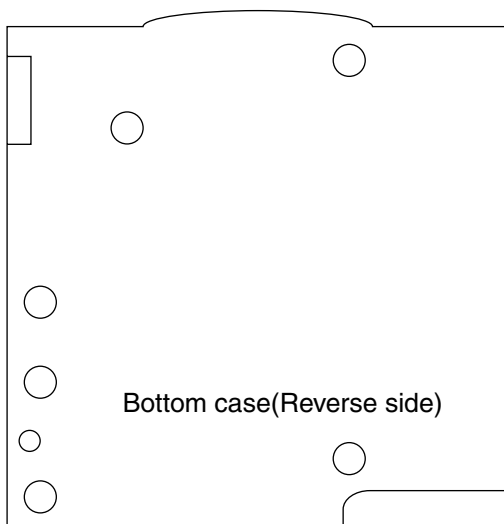

Parts Number	Marking non	Marking have
Bottom case (BU)	LV10423-002A	LV10423-202A
Bottom case (PN)	LV10423-003A	LV10423-203A
MD door assy (BU)	LV32219-002A	LV32219-202A
MD door assy (PN)	LV32219-003A	LV32219-203A

WT is 1 kind of parts.



**XM-PX70WT/BU/PN**

**JVC**

**VICTOR COMPANY OF JAPAN, LIMITED**

AUDIO & COMMUNICATION BUSINESS DIVISION

PERSONAL & MOBILE NETWORK BUSINESS UNIT. 10-1,1chome,Ohwatari-machi,Maebashi-city,371-8543,Japan

(No.20897)

 Printed in Japan  
200101(O)